

SPECIFICATIONS

BBR365-RGGG

Back Bar Heavy Duty 3-Door Chiller - Remote

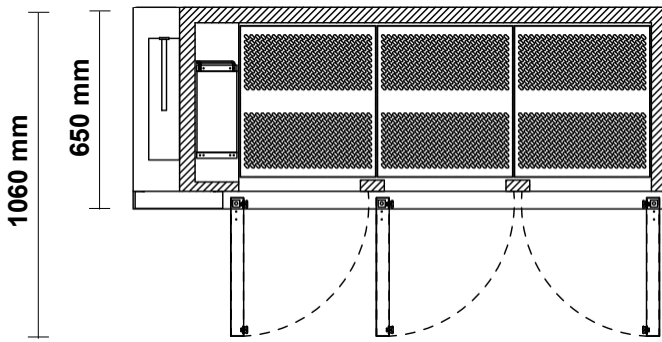
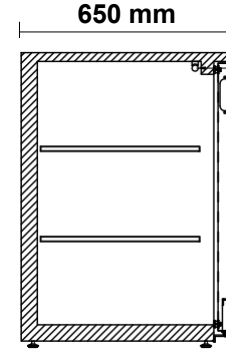
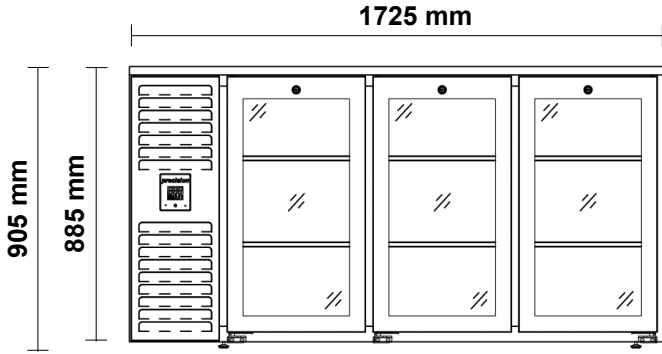

SPECIFICATIONS

Refrigeration system	Electronic controlled, remote, side mounted, refrigeration unit	
Refrigerant	R404a	
Nominal capacity	307 Watts @ -5°C SST	
Cabinet internal volume	738 x 330ml beer bottles	
Insulation	40mm thick, high density Zero ODP injected polyurethane insulation	
Cabinet temperature range	+3°C to +15°C up to 43°C ambient	
Drainage	Waste heat vaporiser located in service compartment (no plumbing required)	
Electrical	220-240 Volts a.c. 50 Hz, 1.4 Amps	
kWh/24hr	n/a	
Internal door opening size	3 door openings, accepts 50 x wine bottles per door (Total 150)	
Doors	Stainless steel, self-closing, glass doors with stylish hidden door handle	
Worktop	Integrated stainless steel worktop	
Shelves	2 perforated SS shelves & adjustable tray slides per door (Total 6)	
Weight	168kg	
Cabinet dimensions	External	
	Width	1725mm
	Depth	650mm
	Height	905mm*

OPTIONS

Exterior Finishes

- Mirrored ST/ST
- Coloured ST/ST
- Black Powder Coat
- Painted (any RAL)

Other

- Solid Doors
- Sliding Glass/ Solid Doors
- Height 845mm / 900mm
- "Skinny" door option for exterior cladding - consult CyberChill Representative
- Bottle drawers
- Castors / Legs (std on adjustable feet)
- Water-cooled
- Extra Shelves
- Heli-coil Cable
- Hydrocarbon Refrigerant
- HFO Refrigerant

* Height includes standard adjustable feet and SS worktop