

SPECIFICATIONS

GCS965

1-Door Glass Chiller (Integral)

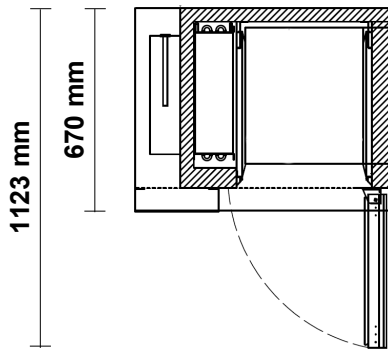
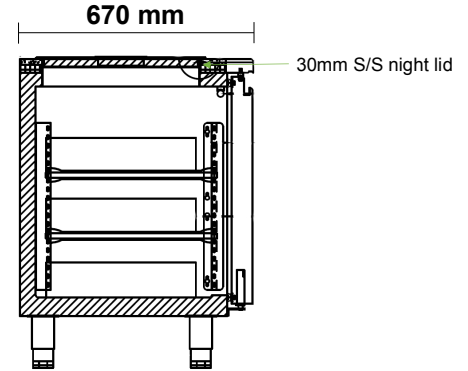
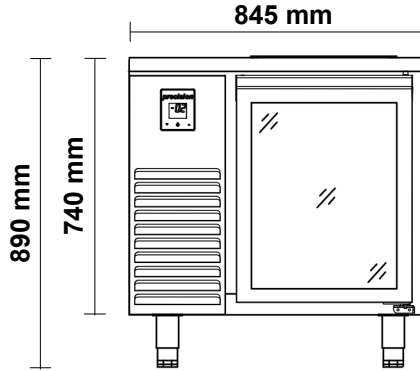

SPECIFICATIONS

Refrigeration system	Electronic controlled, remote, refrigeration unit	
Refrigerant	R404A	
Nominal capacity	400 Watts @ -10°C SST	
Heat rejection	642 Watts	
Cabinet internal volume	150 litres	
Insulation	60mm thick, high density Zero ODP injected polyurethane insulation	
Cabinet temperature range	+1°C to +4°C up to 43°C ambient	
Drainage	Waste heat vaporiser located in service compartment (no plumbing required)	
Electrical	220-240 Volts a.c. 50 Hz, 2.2 Amps	
kWh/24hr	2.4	
Internal door opening size	1 door opening, accepts 3 pcs of 355 x 430 x 100 mm wire basket	
Doors	Stainless steel, self-closing, lockable glass door	
Worktop	Removeable stainless steel worktop	
Shelves	2 shelves & adjustable tray slides per door (Total 2)	
Weight	110kg	
Cabinet dimensions	External	Internal
Width	845mm	444mm
Depth	670mm	550mm
Height	740mm*	605mm

OPTIONS

- Solid Doors
- Remote Units
- Legs / Castors
- Splashbacks
- Extended Worktops
- No Worktop
- Different Heights
- Over-shelf / Gantry
- Water-cooled
- Extra Shelves
- Extra Slides
- ST/ST Back
- Heli-coil Cable
- Hydrocarbon Refrigerant
- HFO Refrigerant

* Height excludes castors, legs or SS worktop