

# SPECIFICATIONS

## HPU152

### Integral 2-Drawer Under Counter Chiller

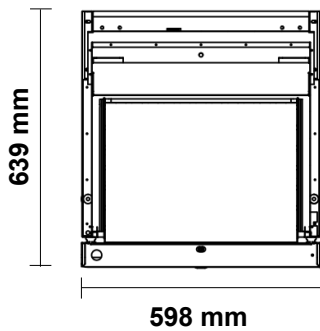
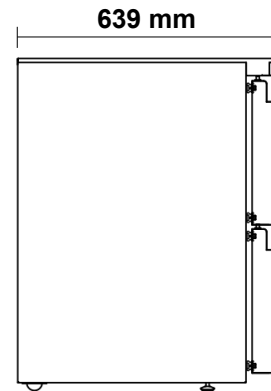
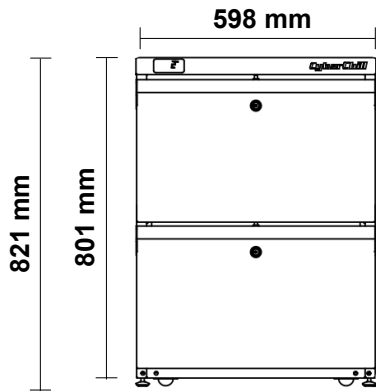

#### SPECIFICATIONS

<b>Refrigeration system</b>	Electronic controlled, self-contained, refrigeration unit
<b>Refrigerant</b>	R134a / 160g
<b>Nominal capacity</b>	307 Watts @ -10°C SST
<b>Cabinet internal volume</b>	77 litres
<b>Insulation</b>	25mm thick, high density Zero ODP injected polyurethane insulation
<b>Cabinet temperature range</b>	+1°C to +4°C up to 43°C ambient
<b>Drainage</b>	Waste heat vaporiser located in service compartment (no plumbing required)
<b>Electrical</b>	220-240 Volts a.c. 50 Hz. 1.0 Amps
<b>kWh/24hr</b>	3.19
<b>Internal door opening size</b>	Bank of 2 Drawers (220/220mm)
<b>Doors</b>	N/a
<b>Worktop</b>	Removable stainless steel worktop
<b>Shelves</b>	N/a
<b>Weight</b>	70kg
<b>Cabinet dimensions</b>	<b>External</b>
<b>Width</b>	598mm
<b>Depth</b>	639mm
<b>Height</b>	801mm*

#### OPTIONS

- Solid Door (HPU150)
- Bank of 3 Drawers (HPU153)
- Glass Door
- Stacking kit Units
- Legs / Castors
- Padlocking facility
- Hydrocarbon Refrigerant
- Helicoil cable
- Extra Shelves
- Extra Slides

#### KEY FEATURES

- Electronic controller with easy read LCD screen
- Off cycle gas defrost
- Door/Drawer locks fitted as standard
- Rifle bore coated evaporators
- Adjustable feet at front
- Rollers at rear for easy positioning
- Required small ventilation gap above unit

\* Height excludes castors, legs or adjustable feet