

SPECIFICATIONS

precision

refrigeration

HUC150

Space Saving Solutions Chiller

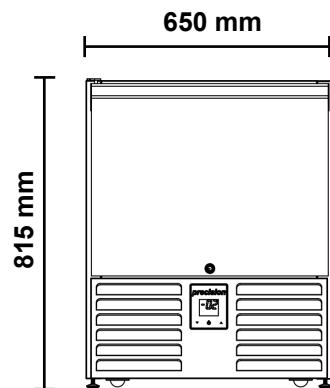

Options:

- Bank of 2 Drawers
- Watercooled
- Extra Shelves
- Extra Slides
- ST/ST Back
- Castors / Legs
- Helicoil Cable
- Hydrocarbon Refrigerant
- HFO Blast Chiller

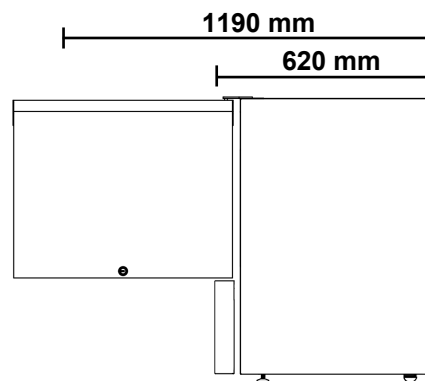

SPECIFICATIONS

Refrigeration system:	Electronic controlled, self-contained, side mounted, refrigeration unit
Refrigerant:	R134a / 160g
Nominal capacity:	460 Watts @ -5°C SST
Cabinet internal volume:	150 litres
Insulation:	40mm thick, high density 0 ODP injected polyurethane insulation
Cabinet temperature range:	1°C to 4°C up to 43°C ambient
Drainage:	Waste Heat Vaporiser located in service comp. (no plumbing required)
Electrical:	220-240 Volts a.c. 50 Hz, 2.5 Amps
kWh/24 hr :	N/A
Internal door opening size:	1 door opening: Accepts full 1/1 GN pans
Doors:	Solid stainless steel, self-closing doors
Worktop:	Removable Stainless Steel Worktop
Shelves:	2 shelves & adjustable tray slides per door (325mm wide x 530mm deep)
Weight:	65 kg

CABINET DIMENSIONS

	External	Internal
Width:	650mm	570mm
Depth:	620mm	410mm
Height:	790mm*	445mm
Floor area:	0.61m ²	

* Height excludes castors, legs or SS worktop

CyberChill