

SPECIFICATIONS

LCU311-UDDD

670 Series 3-Door Integral Counter Freezer

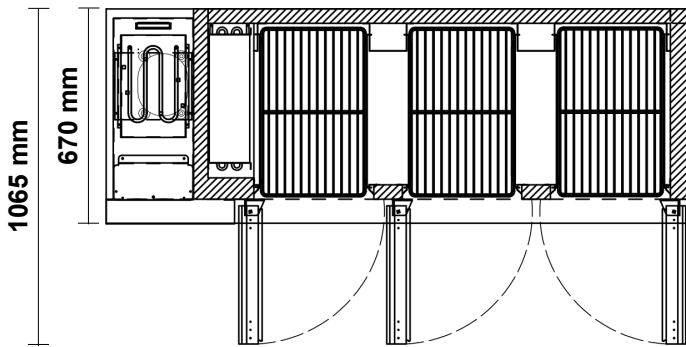
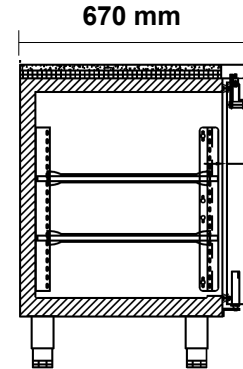
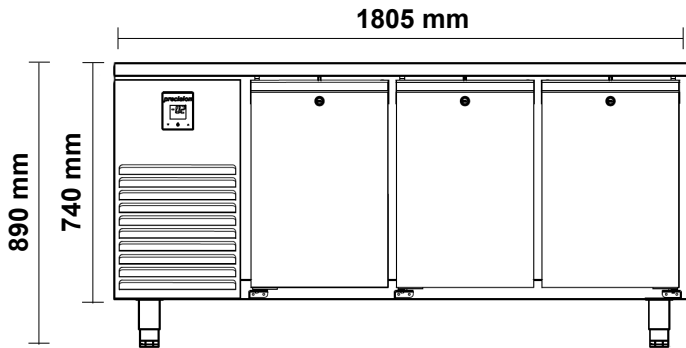

SPECIFICATIONS

Refrigeration system	Electronic controlled, self-contained, side mounted, refrigeration unit	
Refrigerant	R404a / 240g	
Nominal capacity	480 Watts @ -30°C SST	
Cabinet internal volume	253 litres	
Insulation	60mm thick, high density Zero ODP injected polyurethane insulation	
Cabinet temperature range	-18°C to -22°C up to 43°C ambient	
Drainage	Waste heat vaporiser located in service compartment (no plumbing required)	
Electrical	220-240 Volts a.c. 50 Hz, 3.7 Amps	
kWh/24hr	9.43	
Internal door opening size	3 door opening, accepts full 1/1 GN pans (325mm wide x 530mm deep)	
Doors	Stainless steel, self-closing, lockable solid doors	
Worktop	Removable stainless steel worktop	
Shelves	2 shelves & adjustable tray slides per door (Total 6)	
Weight	150kg	
Cabinet dimensions	External	Internal
Width	1805mm	1285mm
Depth	670mm	550mm
Height	700mm*	600mm

OPTIONS

- Glass Doors
- Bank of 2 Drawers
- Bank of 3 Drawers
- Remote Units
- Castors (std on 150mm Legs)
- Splashbacks
- Extended Worktops
- No Worktop
- Different Heights
- Raised Pan Grid
- Countertop Well
- Over-shelf / Gantry
- Water-cooled
- Extra Shelves
- Extra Slides
- ST/ST Back
- Heli-coil Cable
- Hydrocarbon Refrigerant
- HFO Refrigerant

* Height excludes castors, legs or SS worktop