

SPECIFICATIONS

LPU150

Integral 1-Door Under Counter Freezer

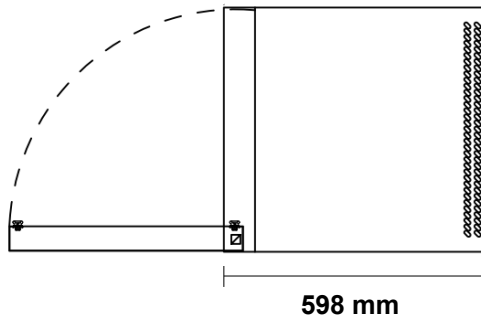
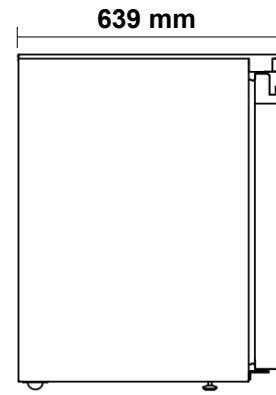
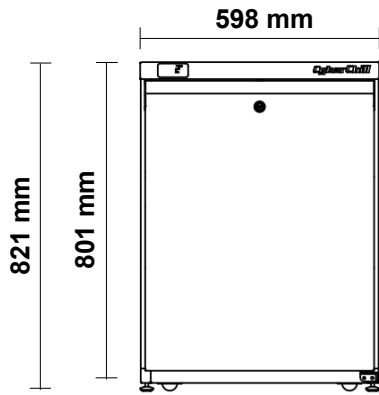

SPECIFICATIONS	
Refrigeration system	Electronic controlled, self-contained, refrigeration unit
Refrigerant	R404a / 240g
Nominal capacity	180 Watts @ -30°C SST
Cabinet internal volume	78 litres
Insulation	25mm thick, high density Zero ODP injected polyurethane insulation
Cabinet temperature range	-18°C to -22°C up to 43°C ambient
Drainage	Waste heat vaporiser located in service compartment (no plumbing required)
Electrical	220-240 Volts a.c. 50 Hz. 0.8 Amps
kWh/24hr	1.3
Internal door opening size	1 door opening: Accepts full 1/1 GN pans
Doors	Solid stainless steel, self-closing doors
Worktop	Removable stainless steel worktop
Shelves	2 shelves & adjustable tray slides per door (325mm wide x 530mm deep)
Weight	60kg
Cabinet dimensions	External
Width	598mm
Depth	639mm
Height	801mm*

OPTIONS
• Bank of 3 Drawers (HPU153)
• Bank of 2 Drawers (HPU152)
• Glass Door
• Stacking kit Units
• Legs / Castors
• Padlocking facility
• Hydrocarbon Refrigerant
• Helicoil cable
• Extra Shelves
• Extra Slides
KEY FEATURES
• Electronic controller with easy read LCD screen
• Off cycle gas defrost
• Door/Drawer locks fitted as standard
• Rifle bore coated evaporators
• Adjustable feet at front
• Rollers at rear for easy positioning
• Required small ventilation gap above unit

* Height excludes castors, legs or adjustable feet