

# SPECIFICATIONS

## MCU211-UDD

### 670 Series 2-Door Integral Counter Chiller

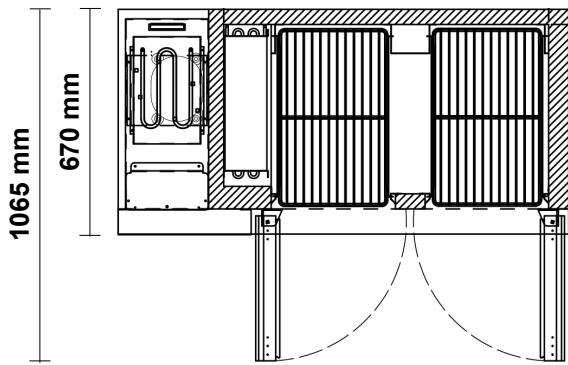
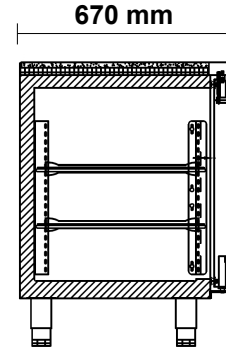
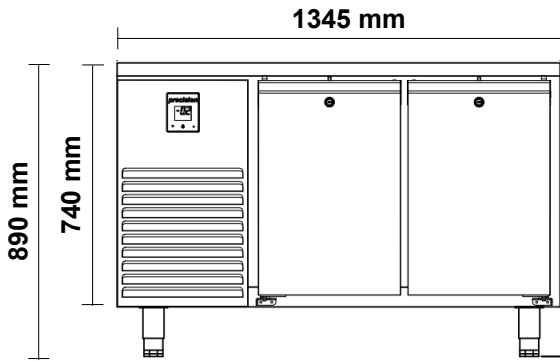

#### SPECIFICATIONS

<b>Refrigeration system</b>	Electronic controlled, self-contained, side mounted, refrigeration unit	
<b>Refrigerant</b>	R134a / 160g	
<b>Nominal capacity</b>	412 Watts @ -10°C SST	
<b>Cabinet internal volume</b>	168 litres	
<b>Insulation</b>	60mm thick, high density Zero ODP injected polyurethane insulation	
<b>Cabinet temperature range</b>	-2°C to +4°C up to 43°C ambient	
<b>Drainage</b>	Waste heat vaporiser located in service compartment (no plumbing required)	
<b>Electrical</b>	220-240 Volts a.c. 50 Hz, 1.6 Amps	
<b>kWh/24hr</b>	1.25	
<b>Internal door opening size</b>	2 door opening, accepts full 1/1 GN pans (325mm wide x 530mm deep)	
<b>Doors</b>	Stainless steel, self-closing, lockable solid doors	
<b>Worktop</b>	Removable stainless steel worktop	
<b>Shelves</b>	2 shelves & adjustable tray slides per door (Total 4)	
<b>Weight</b>	115kg	
<b>Cabinet dimensions</b>	<b>External</b>	<b>Internal</b>
<b>Width</b>	1345mm	825mm
<b>Depth</b>	670mm	550mm
<b>Height</b>	700mm*	600mm

#### OPTIONS

- Glass Doors
- Bank of 2 Drawers
- Bank of 3 Drawers
- Remote Units
- Castors (Std on 150mm legs)
- Splashbacks
- Extended Worktops
- No Worktop
- Different Heights
- Raised Pan Grid
- Countertop Well
- Over-shelf / Gantry
- Water-cooled
- Extra Shelves
- Extra Slides
- ST/ST Back
- Heli-coil Cable
- Hydrocarbon Refrigerant
- HFO Refrigerant

\* Height excludes castors, legs or SS worktop